

500x600 mm rack
MULTIPURPOSE WASHERS

Prime Line

Up for the Challenge

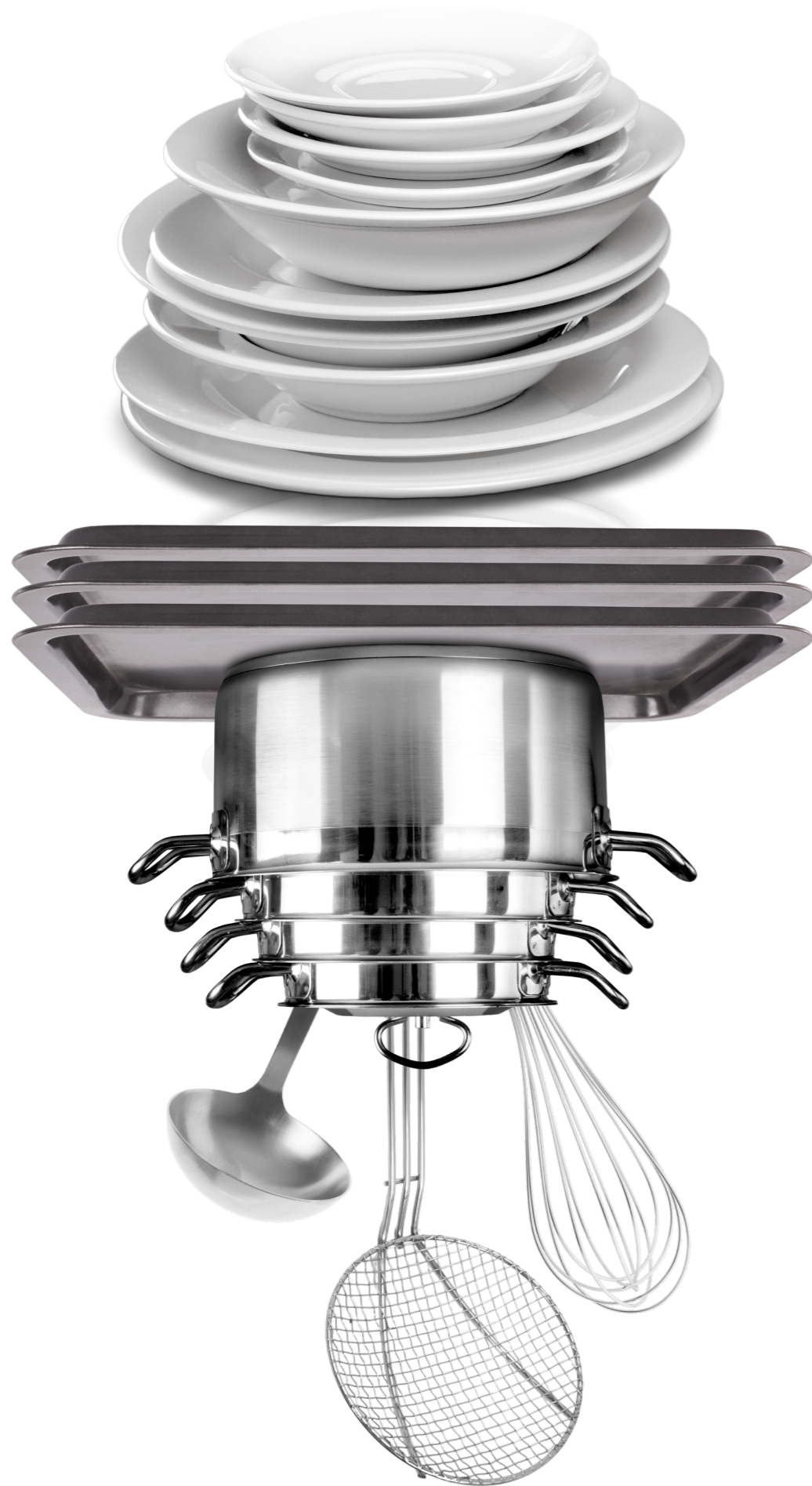



SIZE MATTERS!

Sometimes it is best to get out of the ordinary.

If the standard doesn't satisfy your needs, you need to "think bigger" and outside the box.

That's why among our range of **compact solutions we've designed MULTIPURPOSE WASHERS with extra large rack size and clearances.**

It means you can wash a multitude of items, while saving time and space.

A reliable ally for:

- **FOOD PREPARATION:** It's perfect to wash kitchen utensils, baking trays and pans, planetary mixed bowls and containers.
- **SERVICE:** It washes crockery, cutlery and glassware very quickly and you can focus on your customers.



PRIME LINE

Two different models with an **extremely compact design** and a great washing capacity to face even the most aggressive dirt.

PF46 R

Front loader dishwashers
Multipower,
500x600 mm rack,
and 400 mm clearance
Ideal for under counter
installation in case of
space constraint or on a
stand



PF46 R B-GREEN

Front loader dishwashers
Multipower,
500x600 mm rack,
and 400 mm clearance
Multipurpose washer,
dishwasher &
bottlewasher: 2 in 1



PFS90 R

Front loading standalone multipurpose washer
Multivoltage,
500x600 mm rack,
and 500 mm clearance



BUSINESS AREAS

FAST FOOD/ QSR



CARE SECTOR



GHOST KITCHEN & DELIVERY



SMALL RESTAURANTS & BISTROTS



EVENTS & SHOW COOKING



PASTRY SHOP



BAKERY SHOP



☼ Ideal for tight spaces where you need to make the most of every inch! ☼



FEATURES

DURABILITY

- **Single skin body in AISI 304**
- **Molded** double skin insulated door
- **Rear panelling**







FLEXIBILITY

- **Multipower** solution (PF46 R) - **Multivoltage** solution (PFS90 R)
- Hood activated cycle start and manual cycle start
- **Provision for drain pump**
- **Soft Start:** The cycle starts slowly and gradually builds to full speed to prevent the dislodging of light items like glassware and crockery and consequently breakage (PF46 R)
- Fast programming of the control panel upon installation to establish **specific times, temperatures and detergent requirements.**
- **Built-in detergent and rinse-aid dosing pumps.**



HYGIENE

- **Single piece deep drawn tank:** multiple filtration system (whole tank filter and pump suction filter)
- **Self-cleaning cycle at unit switch-off**
- **Wire rounded rack guides:** no blind spots during operations

-  Initial tank fill
-  Ready to go
-  Cycle on
-  Alarm



SAFETY

- **Magnetic microswitch to stop the cycle in case of accidental door opening**
- Adjustable Thermostop as a standard: it ensures that the correct operating temperatures are reached
- **Temperature measurement via electronic probes: accuracy and reliability. Allows the operator to read the real and the set point temperatures on the display.**

POWER AT YOUR FINGERTIPS

- Display with temperature indicators
- 4 programming options for washing cycles (Eco fast, Glasses, Dishes, Intensiv / Bottles & Jugs)
- **Diagnostics with alphanumeric alarm codes**
- **Cycle progress with alphanumeric countdown**
- **Cycles and performances counter:** allows the technician to plan maintenance. Useful for statistics and usage informations.
- **Colour-coded status indicators.**



FEATURES

STANDARD

WASHING AND RINSE SYSTEM

Stainless steel rotating upper and lower wash and rinse arms are designed to guarantee outstanding results.

PF46 R -
Stainless steel wash and rinse arms

PFS90 R -
Separate stainless steel wash and rinse arms



STANDARD

500X600 MM RACK & OVERSIZED CLEARANCE

With 400 mm and 500 mm clearance **dishes, crockery, trays and containers of any shape and size can be easily washed.**

Thanks to our 600x500mm rack you can upgrade your washing capacity.

Quicker turnaround for your kitchen utensils and supplies as well as crockery and cutlery, serving trays, meal trays.



XLB



XLP



XLT

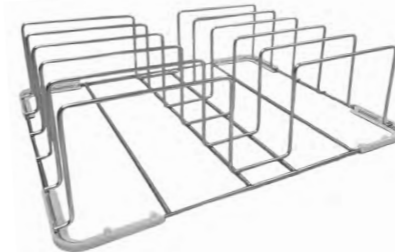

RACK FOR 5 BAKE PANS



POTS AND PANS



BOWLS



TRAYS
600 x 400 mm



SMALL KITCHEN UTENSILS



CONTAINERS



DISHES, MUGS & CUPS



FEATURES

STANDARD

RCD - RINSE CONTROL DEVICE

The RCD System, standard for model PF46 R and PFS90 R, maintains constant water pressure and temperature throughout operations.

The highest levels of hygiene and sanitisation are achieved through high washing and rinsing temperatures along with contact times in line with the DIN 10534 standards.

RCD: how it works

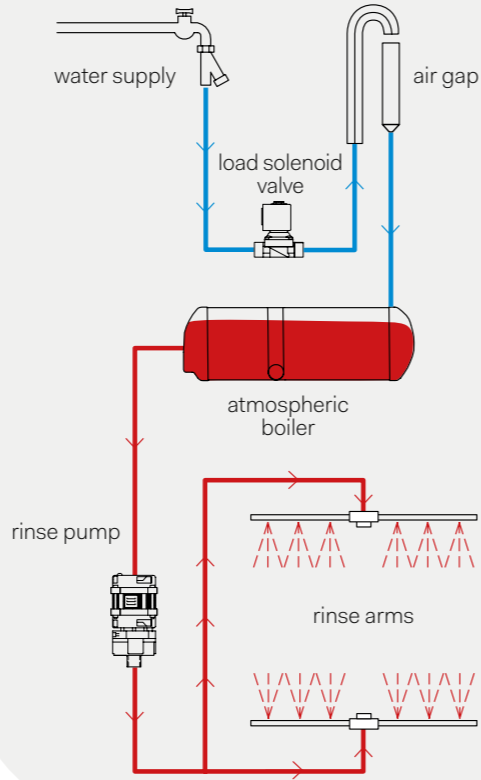

COMPLETE YOUR UNITS

OPTIONAL

CRC- HEAT RECOVERY SYSTEM

Available as an option for model PFS90 R, CRC enables the machine **to be connected to cold water at 15°C booster.**

CRC allows for consistent energy savings.

Minimizing the steam released, CRC helps create a more comfortable work environment.

Ventless Execution

-35%

energy

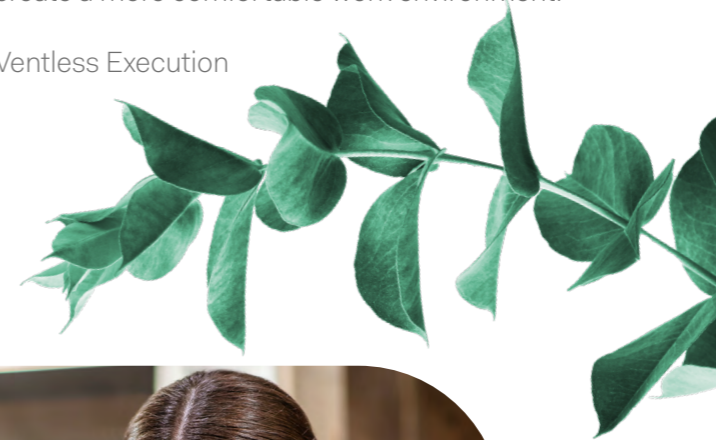

+ EXECUTION



Prime Line also available in the "+" execution with built-in drain pump and detergent dosing unit, rinse aid dosing unit





COMPLETE YOUR UNITS

OPTIONAL

WI-FI CONNECTION & REMOTE MONITORING

The new **Wi-Fi Pack** available for both PFS90 R and PF46 R models, **allows the operator to easy monitoring the machine functions** and access a vast amount of information; **prevent possible failures by managing the anomalies in real time from smartphone, tablet and PC** and keep consumptions under control. The continuous monitoring of water, chemicals and energy consumption leads to a more environmentally conscious us of world's natural resources.

INDUSTRY 4.0



COMENDA CLOUD WASHING DASHBOARD WEB

Simple and intuitive gives you the power to:

- Check the main operating parameters of the unit;
- Start/stop the washing cycle;
- Download Records and HACCP reports;
- Access the alarm list and manage the anomalies;
- Check and download technical documentation.





B-GREEN EXECUTION: DISHWASHER & BOTTLE WASHER: 2 IN 1

The new Comenda PF46 R B-Green execution offers an efficient solution to clean refillable bottles and carafes.

Durable and reliable B-Green is designed to satisfy multiple washing needs during service.

Thanks to the Comenda innovative B-Green rack, with quick-coupling hooks included, you can load the machine with a single gesture!



Supporting operators going plastic free by moving from a single-use plastic bottles consumer role to a zero-waste ambassador.

The practical sensing probes will activate a separate hydraulic circuit, allowing the automatic selection of the dedicated programme, for perfect cleaning of your bottles and jugs!

Just remove the bottle rack and use one of the many standard 500 x 600 mm racks to wash dishes, glasses, cutlery and kitchen utensils.

**YOU CAN WASH UP TO
16 BOTTLES OR 9 JUGS
FOR CYCLE!**





AT YOUR SIDE SINCE 1963

As the parent company of Ali Group, Comenda offers professional washing machines rigorously **“Made in Italy”**, according to the highest quality standards.

Comenda solutions range from small-sized cup and glass washers for bars to large, automated, continuous feed systems for restaurants, hospitals, canteens and inflight catering.

Our operational flexibility allows us to supply **tailor-made systems**, designed to meet individual space and operation requirements, without any limits on processing capacity, **granting the highest standards of hygiene.**

Championing exceptional performance, cost containment and highly energy efficient design since 1963



SPEED. SERVICE. SOLUTIONS.



There's no time for downtime in your operations. That's why our products are designed to facilitate quick turnarounds and replacements.

Comenda ensures rapid response and complete client service.

Our extensive network of distributors and service providers are ready to assist when in need.



ORIGINAL SPARE PARTS 24/7

You can order directly from our website and check real-time parts availability, **24 h a day and 7 days a week.**

On our website you can: **access and download** technical documentation on our machines (product manuals and detailed electrical and hydraulic schematics); find answers to the most frequently asked questions and **watch Comenda video tutorials.**

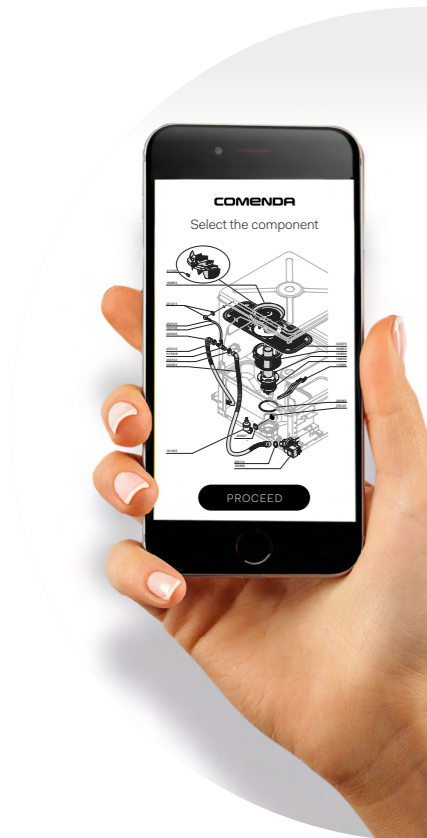

NEVER STOP TRAINING

To support the ongoing training of our distributor and service network, we encourage our partners to attend our in-house, hands-on seminars. Ask our team for specific onsite training for operators and staff.





TECHNICAL DATA

PF46 R

Multipurpose undercounter units



	PF46 R*	PF46 R B-GREEN*
EXTERNAL DIMENSIONS (AxBxC) (mm)	600 x 695 x 830	600 x 695 x 830
OVERALL SIZE (D) (mm)	1150	1150
RACK SIZE (mm)	500 x 600	500 x 600
CLEARANCE (E) (mm)	400	400
ELECTRICAL SUPPLY (V)	230V ~ 50Hz, 230V/3 ~ 50Hz; 400V/3N ~ 50Hz	230V ~ 50Hz, 230V/3 ~ 50Hz; 400V/3N ~ 50Hz
PROGRAM LENGHT (sec)	120/180/240/480	120/180/240/260*
OUTPUT RACKS (rack/h)	30/20/15/8* 23/20/15/8*	30/20/15/14** 23/20/15/14**
RINSE WATER CONSUMPTION (l/cycle)	3,5	3,5
TANK HEATER ELEMENTS (kW)	2	2
BOOSTER HEATER (kW)	7	7
TANK SIZE (l)	23	23
WASH PUMP (kW)	0,83	0,83
INSTALLED LOAD (kW)	7,83	7,83

OPTIONAL

- DRAIN PUMP KIT
- EXTERNAL WATER SOFTENER
- SPECIAL VOLTAGES
- PROVISION FOR PEAK POWER REDUCTION CONNECTION
- BASE STAND WITH DOOR FOR PF46 H 430MM + 7 MM FEET
- WI-FI CONNECTION & REMOTE MONITORING

- With RCD
- Output racks - cold water connection (15°C)
- Output racks - hot water connection (55°C)
- * Water bottles and jugs dedicated cycle

PF46 R

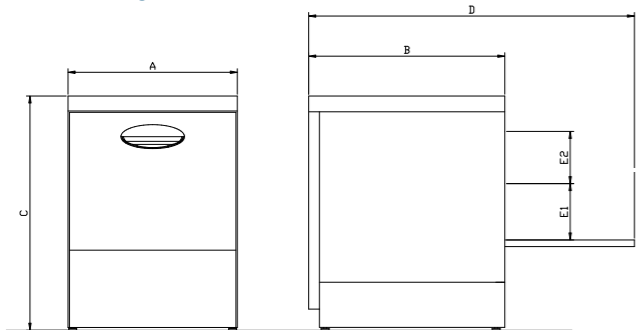

PF 46 R B-GREEN

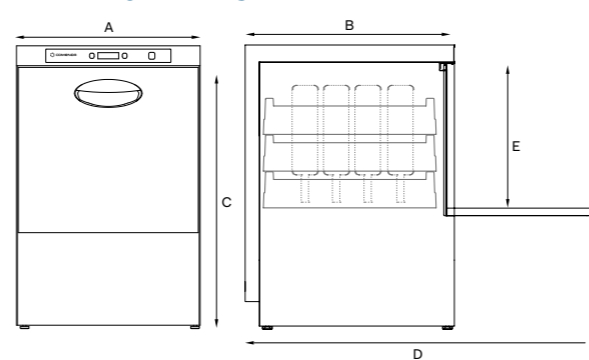

The following non-binding information refers to the ideal operating conditions of the machines. The values indicated may vary depending on the installation conditions and the items washed: the operator is responsible for selecting the correct washing cycle and speed according to the amount of dirt on the dishes, based on the washing and rinsing results achieved and to be obtained. Depending on local conditions (incoming water temperature / power supply), the values indicated here may be modified. The actual rinse water volume may vary according to local conditions. Comenda Ali Group srl reserves the right to modify product specifications at any time without prior notice.



TECHNICAL DATA

PFS90 R

Multipurpose undercounter units



	PFS90 R*
EXTERNAL DIMENSIONS (AxBxC) (mm)	620x742x1530 620x742x1960(F)
OVERALL SIZE (D) (mm)	1375
RACK SIZE (mm)	500 x 600
CLEARANCE (E) (mm)	500
ELECTRICAL SUPPLY (V)	230V/3 ~ 50Hz; 400V/3N ~ 50Hz
WASH PROGRAM LENGHT (sec)	90/120/240/480
OUTPUT RACKS (rack/h)	32/30/15/8* 16/16/15/8*
RINSE WATER CONSUMPTION (l/cycle)	4
TANK HEATER ELEMENTS (kW)	3
BOOSTER HEATER (kW)	6
TANK SIZE (l)	42
WASH PUMP (kW)	1,5
INSTALLED LOAD (kW)	7,5

OPTIONAL

- DRAIN PUMP KIT
- EXTERNAL WATER SOFTNER
- SPECIAL VOLTAGES
- PROVISION FOR PEAK POWER REDUCTION CONNECTION
- WI-FI CONNECTION & REMOTE MONITORING
- CRC - HEAT RECOVERY SYSTEM

- With RCD
- Output racks - cold water connection (15°C)
- Output racks - hot water connection (55°C)

PFS90 R

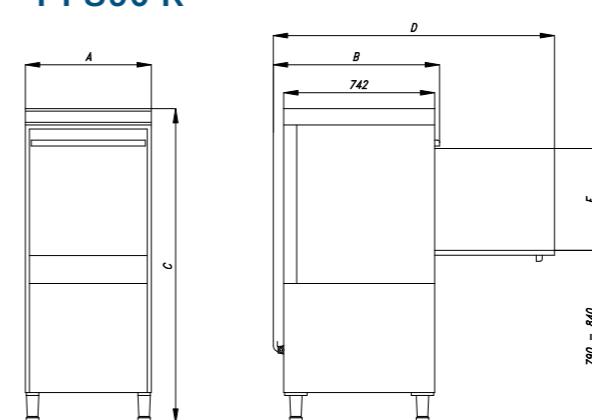

PFS90 R CRC

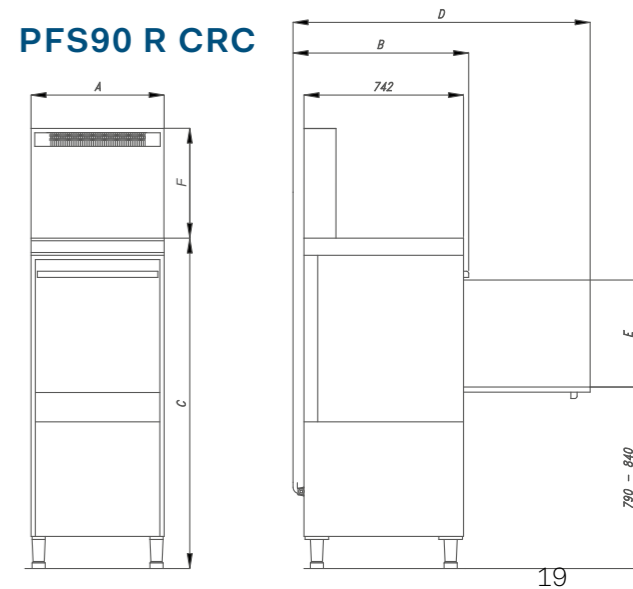

CONTACTS

Comenda Ali Group

Via Galileo Galilei 8
20051 Cassina de' Pecchi (MI)

Italia

T +39 02 952281

sales@comenda.eu

www.comenda.eu



Azienda con sistema di gestione qualità/ambiente certificato
secondo le norme ISO9001 e ISO14001:2015.

*Comenda complies with ISO9001 quality management system
and ISO14001:2015 environmental management system.*

Cod. 90002011122 - Con riserva di variazione delle caratteristiche tecniche. Foto non vincolanti.





an Ali Group Company



The Spirit of Excellence